

IRONMONGERY AND ACCESSIBILITY

GAI SPECIFIER'S GUIDE

The specifier's guide to specifying architectural ironmongery to meet the best practice guidelines of accessibility and inclusive design.

IRONMONGERY AND ACCESSIBILITY

GAI SPECIFIER'S GUIDE

Based on the RIBA Approved CPD of the same name, the specifier's guide to Ironmongery and Accessibility covers specifying architectural ironmongery to meet the best practice guidelines of accessibility and inclusive design.

If you would like to receive a presentation of the CPD, this is available through GAI member companies. Please visit the GAI website (gai.org.uk) for more details.

CONTENTS

1. LEGISLATION	Page 3
2. PRODUCT SPECIFICATION	Page 4
3. OPENING FORCE CONSIDERATIONS	Page 5-6
4. CLEAR OPENING WIDTH	Page 7
5. LEVER HANDLES	Page 8
6. PULL HANDLES	Page 9
7. LOCKS, LATCHES & THUMBTURNS	Page 10
8. MISCELLANEOUS HARDWARE	Page 11
9. VISUAL CONTRAST & LRV	Page 12

SPONSORED BY



1. LEGISLATION

To have a full understanding of the issues related to ironmongery and accessibility, it is imperative to recognise the legislation that is in place that apply specifically to this area of architectural ironmongery.



DEFINITION OF DISABILITY

'A physical or mental impairment which has a substantial and long-term adverse effect on a person's ability to carry out day-to-day activities.'

This includes many more people than suggested by the symbol of a wheel chair user.

DISABILITY DISCRIMINATION ACT (DDA)

The DDA was introduced in a number of stages starting in December 1996. From October 1999 it required "service providers" to take reasonable steps to change practices, provide auxiliary aids, and remove physical barriers to make their facilities more accessible for users with disabilities.

From October 2004, they have had to "make reasonable adjustments to the physical features of their premises, if it is impossible or difficult for disabled people to access their service" i.e. all existing buildings had to be upgraded where practical and reasonable. All new buildings and extensions must comply.

THE EQUALITY ACT

The Equality Act (EA) came in to force on 1st October 2010. All civil rights legislation covering discrimination of various kinds (including the DDA, Sex Discrimination Act, Race Discrimination Act, etc.) was amalgamated into the Equality Act.

This consolidated 116 different pieces of equality legislation, 35 Acts of parliament, 52 Statutory Instruments, numerous Codes of Practice and 16 EC Directives and Recommendations. Combined, they provide a legal framework to protect the rights of individuals and advance equality of opportunity for all.

It has a much wider remit than the building regulations, applying as it does to owners and operators of all buildings, new and existing, that lie within its scope. With respect to providing suitable access and facilities for people with a disability, consideration should be given to equality requirements.

Equality law recognises that bringing about equality for disabled people may mean changing the way in which services are delivered, providing extra equipment and/or the removal of physical barriers. This is the 'duty to make reasonable adjustments'.

This aims to make sure that a disabled person can use an organisation's services as close as it is reasonably possible to the standard usually offered to non-disabled people.

If an organisation providing goods, facilities or services to the public or carrying out public functions, or running an association identifies barriers to disabled people in how it does things, it must consider making adjustments. If those adjustments are reasonable for that organisation to make, then it must make them.

The duty is 'anticipatory'. An organisation cannot wait until a disabled person wants to use its services, but must think in advance (and on an ongoing basis) about what disabled people might reasonably need.

WHAT IS 'REASONABLE'?

The Equality Act mentions "reasonable adjustments" yet it is impossible to list a solution for every door type within every building, so we are pointed in the direction of existing legislation to give us guidance on best practice:

- Approved Documents relating to Building Regulations.
- BS 8300-1:2018 Design of an accessible and inclusive built environment External Environment: Code of Practice.
- BS 8300-2:2018 Design of an accessible and inclusive built environment. Buildings.: Code of Practice.

WHAT IS AN APPROVED DOCUMENT?

Approved Documents are a series of documents that give practical guidance about how to meet the requirements of Building Regulations.

Approved documents set out what, in ordinary circumstances, may be accepted as reasonable provision for compliance with the relevant requirements of the Building Regulations.

Different regions of the UK and Ireland have different interpretations, with their own versions of approved documents.

- England: Approved Document M (2015).
- Wales: Approved Document M (2014).
- Scotland: Technical Handbook, domestic and non-domestic: Safety (2015).
- Northern Ireland: Technical Booklet Part R (2012).
- Republic of Ireland: Technical Guidance Document M (TGDM) (2010).

2. PRODUCT SPECIFICATION

In order to meet the best practice guidelines for accessibility as set out in BS 8300-1 & 2, it is important to consider the specification options for the following architectural ironmongery items.

DOOR FURNITURE

- Lever/pull handles.
- Dimensions and shapes.
- Fixing heights.

LOCKS

- Locks and latches.
- Keys and thumbturns.
- Access control entry systems.

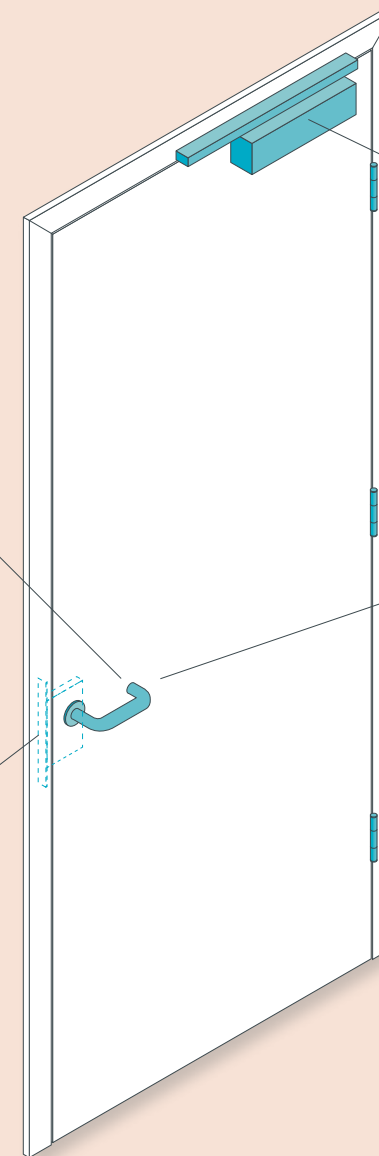

DOOR CLOSING DEVICES

- Opening forces.
- Alternatives to mechanical closers.
- Clear opening widths.

LIGHT REFLECTANCE VALUES

- Visual contrast.
- Door furniture.
- Handrail and signage.

MISCELLANEOUS HARDWARE

- Hinges.
- Panic hardware.
- Door viewers.
- Handrail.



Plunger type force gauge

3. OPENING FORCE CONSIDERATIONS

The prime role of a mechanical door closer is to ensure that a door returns to the closed position after it has been used, generally on fire doors. The forces applied by door closers can sometimes make it difficult for users to open the door and these forces need to be carefully considered.

RECOMMENDED OPENING FORCES FOR DOORS

BS 8300-2 states "For most disabled people to have independent access through single or double swing doors the opening forces when measured at the leading edge of the door should be:

- not more than **30N** from **0°** (the door in the closed position) **to 30° open**.
- not more than **22.5N** from **30° to 60°** open.

It is also stated that it is preferable that backchecks should not operate before about 80° open and that the maximum closing force should occur between 0° and 15° of final closing.

MEASURING OPENING FORCES

Advice also notes that it can be difficult to measure the force at the door edge and that it can be measured in line with the handles, up to 65mm from the door edge.

The figures can be increased by up to 2N in this situation. It is recommended that plunger type force gauges should be used but that they may only have an accuracy to within 2 or 3N.

FURTHER CONSIDERATIONS

There are other considerations which need to be considered when looking at opening forces:

Approved Document B (Fire Safety)

Self-closing device – capable of closing the [fire] door from any opening angle and against any latch fitted to the door.

BS EN 1154 (Controlled Door Closing Devices)

Minimum closing force 18 Nm, so ex-factory settings usually around 20 Nm.

BS EN 1634-1 / BS 476-22 (Fire Resistance Tests)

Unlatched doors must be held closed against fire-generated pressures.

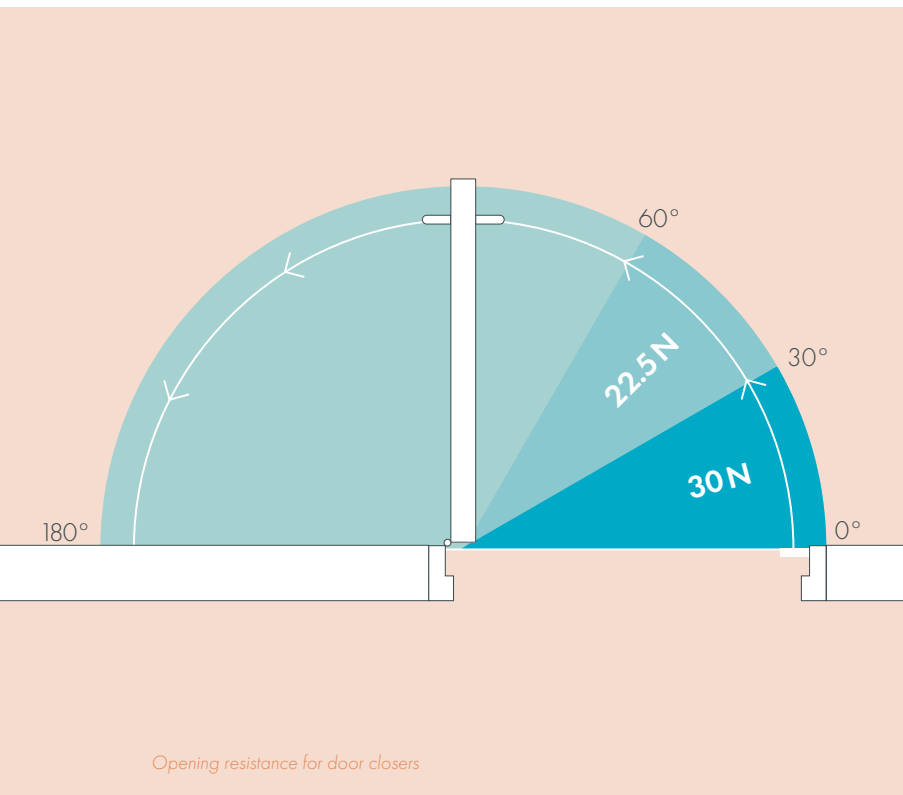

3. OPENING FORCE CONSIDERATIONS CONT'D



Power operated revolving doors

Where it is not possible for a controlled door closing device to close a door and keep it closed without exceeding the opening force limits as mentioned in BS 8300 - 2, then the following systems should be considered.



Motion sensor activated power operated door

SWING FREE DEVICES

Swing free closing devices allow a door to operate without resistance, as if the closer were not present. This means the door can be left in any position.

Once the fire alarm is activated electromagnetic control will release the door, this enables the door to close securely.

Devices must be tested to BS EN 1155 which is a harmonised standard. They are available in overhead, concealed in door and floor springs. New models are now available featuring an anti-slam finger protection function.

POWER-OPERATED DOORS

A power-operated door – either sliding, folding, balanced or swing, which should be one of the following two types:

- A manually activated door controlled by a push pad, coded entry system, card swipe or remote control device.
- An automatically activated door controlled by a motion sensor or a hands-free proximity reader.

Note that installation of automatic operators must be to BS EN 16005.



Electro magnetic hold open closers

ELECTROMAGNETIC HOLD OPEN UNITS

Electromagnetic hold open units are used to hold open fire doors on circulation routes. Their performance is dependent upon doors being closed at the time of fire.

These units can be either in an electro-magnetic unit or else as using an independent electro-magnet. They can be surface or flush mounted.

Devices must be tested to BS EN 1155 which is a harmonised standard. Single swing doors require closing devices that conform with BS EN 1154.

POWER-OPERATED REVOLVING DOORS

Power-operated revolving doors are not considered accessible. Therefore a complementary accessible door should be provided immediately adjacent to the revolving door.

4. CLEAR OPENING WIDTHS

CLEAR OPENING WIDTHS

To enable sufficient space for all users to pass through doorways easily, BS 8300-2 states the minimum effective clear widths for a number of different applications for both new and existing buildings.

Door openings must meet certain critical dimensions for minimum effective clear opening width with the door standing at least 90°.

This applies to all forms of hanging:

- Single axis hinges.
- Single & double action pivots.
- Floors springs.
- Sliding doors.
- Revolving doors.

The clear opening width is measured from the frame stop on the door closing side to the first physical feature on the hinge side.

This obstruction might be;

- the face of the door,
- the hinge-side frame stop,
- projecting door furniture,
- a weatherboard.

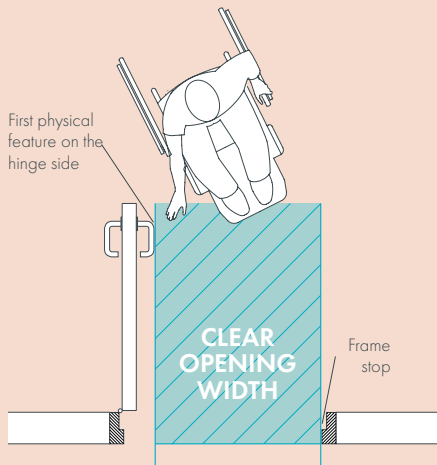

Clear opening width

MINIMUM EFFECTIVE CLEAR WIDTHS

This table from BS 8300-2 (below) shows the minimum effective clear widths for both new and existing buildings.

An accompanying note identifies that effective clear widths of 800mm and 825mm are achievable with 926mm wide doors, provided doors open beyond 90°, and the projection of any door furniture does not reduce effective clear width.

DIRECTION AND WIDTH OF APPROACH	NEW BUILDINGS
Straight on (without a turn or oblique approach)	800mm
At right angles to an access route at least 1500mm wide	800mm
At right angles to an access route at least 1200mm wide	825mm
External doors to buildings used by the general public	1000mm

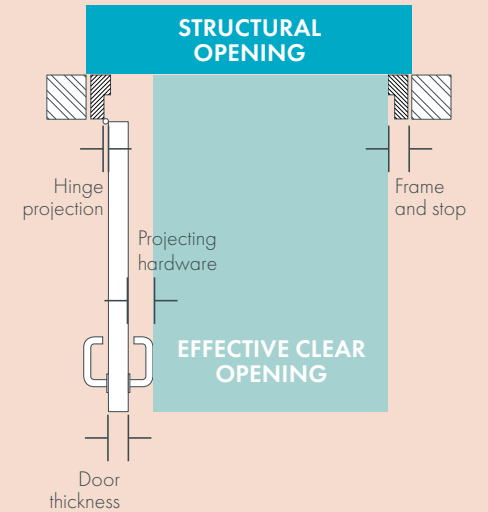

Structural opening width



5. LEVER HANDLES

DIMENSIONAL GUIDELINES

BS 8300 stipulates a number of dimensional guidelines that the design of lever handles should adhere to as follows:

- Hand grip zone – Minimum 95 mm.
- 45 mm from face of door to back of handle.
- Lever section - Minimum 19 mm \varnothing .
- Minimum backset - 54 mm.
- Lever design either - return to door OR with upturn.

These recommendations were created so that lever handles designs;

- allow the whole hand to hold the lever.
- are easy to hold without gripping.
- clear the frame-stop on closing face.
- stop hands sliding off and prevents clothing catching on the handle.

LEVER HANDLE DESIGNS

It should be noted that the round bar, return-to-door safety lever was never mandatory. It exemplified the optimum features, however many projects specified a return to door shape because this was the example used to demonstrate the dimensional guidelines in BS 8300-2.

Lever designs used as examples in BS 8300-2 are indicative only and any designs meeting the dimensional guidelines will be acceptable.

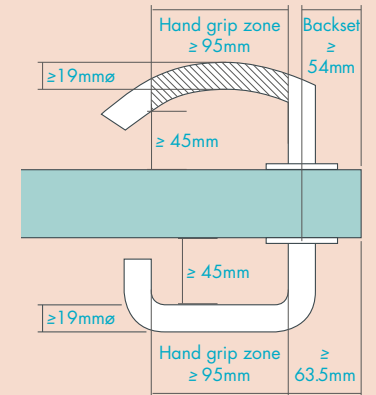

BS 8300 dimensional guidelines

FURTHER RECOMMENDATIONS

The fixing height for lever furniture in BS 8300-2 Clause 6.5.1 is:

- 800-1050mm from finished floor level (with 900mm being the preferred height).

It also states that where lever furniture intercepts glazed viewing panels, any projecting glazing beads should not interfere with the operation of the lever or reduce the effective clearance behind it.

Under BS 8300:2009 the use of knobs and small symmetrical turns should be avoided. Gripping and twisting can be difficult. Knobs with a spherical, circular or similar design are difficult to use by people with limited dexterity.

It should be possible to operate all door opening furniture one-handed, without the need to grasp or twist. Wherever possible, door opening furniture used in conjunction with locks or latches should have lever action.

6. PULL HANDLES

DIMENSIONAL GUIDELINES

BS 8300-2 states that pull handle designs should meet the following dimensional criteria:

- Vertical pull handles should have a section diameter of between 19 mm and 35 mm.
- Horizontal pull rail to help people close the door behind them.

In addition to the above dimensions, the pull handle should be fixed to the door at a height so that it can be reached by all users. The fixing criteria is as follows:

- The bottom fixing of the pull handle should be fixed no lower than 700 mm and no higher than 1000 mm above the finished floor level.
- The top fixing of the pull handle should be fixed no lower than 1300 mm above the finished floor level.

This therefore means that the minimum distance between fixing centres of the pull handle is 300 mm.

PULL HANDLES ON NARROW STILE DOORS

When fitted to doors with narrow stiles, pull handles should adhere to the following:

- Fixing centres close to door edge.
- Doors with narrow stiles require cranked pull handles with an offset of not less than 50 mm from the door edge.

NOTE: Although the conventional "D" pull handle is shown in the figure, other patterns of pull handle are acceptable, provided they conform to the dimensional criteria.

FURTHER RECOMMENDATIONS

- BS 8300-2 stated that the location and design of latch and push/pull handles should be consistent throughout a property.
- As a principle, pull handles should not be fitted to the push side of doors (i.e. fitted "back to back").

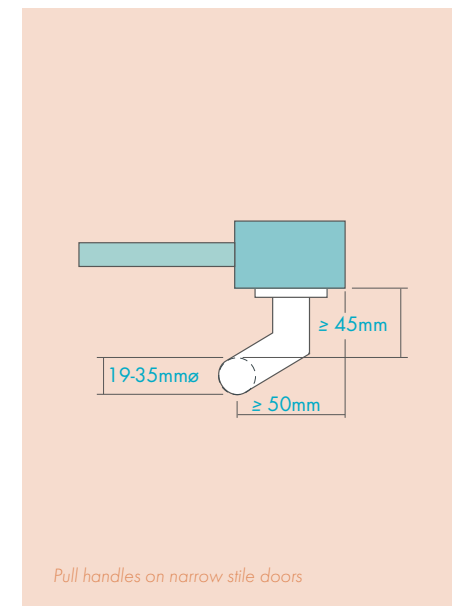
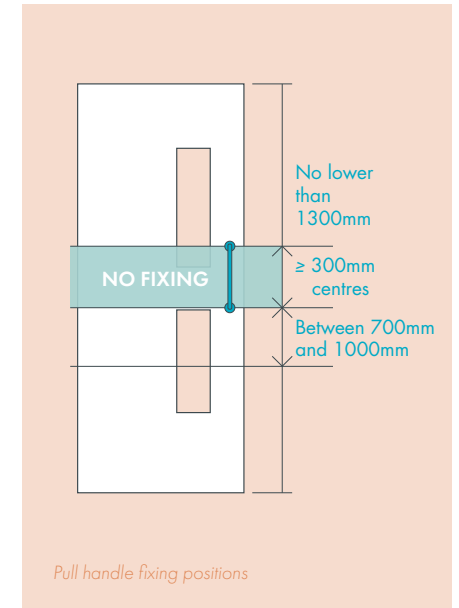

7. LOCKS, KEYS AND THUMBTURNS

The operation of locks and latches can prove difficult for the visually impaired and those with limited dexterity. BS 8300 provides recommendations on the usage of locks and latches to aid the correct specification of these items.

BS 8300 lock dimensional guidelines

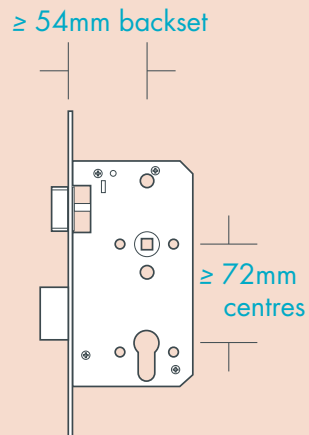

MORTICE LOCKS & LATCHES

To ensure that blind and partially sighted people and/or people with limited dexterity have unobstructed access to the keyway of a lock, the cylinder should be;

- positioned above the lever handle where it is more visible and accessible.

OR

- if the cylinder is below the handle, the minimum distance between the handle and the keyway of the locking mechanism should be 72mm.

In addition, lock cases should have a minimum backset of 54mm to allow enough room between the keyway/handle and the door frame.

KEYS & THUMBTURNS

BS 8300-2 state that cylinders should conform to BS EN 1303 and also adhere to the following:

- It should be possible to operate all door furniture without the need to grasp or twist – this impacts certain designs of thumbturns.
- The torque force required to operate keys and thumbturns should not exceed 0.5 Nm.
- The provision of a larger bow on the lever gives users greater control.
- A hand-grippable key fob can be added to a standard key-bow.



Digital locks with lever

ACCESS CONTROL - DIGITAL LOCKS

- When installed for access control digital locks these should preferably be operated by levers.
- Digital locks should be positioned between 900mm and 1050mm from the finished floor level.

ACCESS CONTROL - ENTRY SYSTEMS

- Door entry systems should be located on the adjacent wall to the door.
- The activation unit should be positioned within 200mm of the door frame, at a height of 900mm to 1050mm from finished floor level.
- Entryphones should be sited for approach and use from a wheelchair.
- They should contain a LED display to assist deaf and hard of hearing. (Note. Video units provide additional benefit for those answering as well as those seeking entry).

8. MISCELLANEOUS HARDWARE

BS 8300-2 touches on a number of different hardware items. Although not in the same finite detail as door furniture, the recommendations stipulated should still be adhered to.

Hinges with low friction bearings



HINGES

- Single axis hinges should conform to the requirements of BS EN 1935.
- Hinges with low friction bearings should be selected where opening force is to be minimise.

PANIC AND EMERGENCY EXIT HARDWARE

- Panic exit devices to BS EN 1125:2008 have been referenced in BS 8300-2.
- Emergency exit devices to BS EN 179:2008 have also been referenced in BS 8300.

DOOR BOLTS - ACCEPTABLE TYPES

- Sunk slide bolts should be avoided.
- Bolts should conform to BS EN 12051.

DOOR VIEWERS

On accessible bedrooms a wide angled viewer should be provided and fitted at two heights:

- 1050mm and,
- 1500mm above floor level.

This allows viewing from those who are seated and standing.



Door bolt

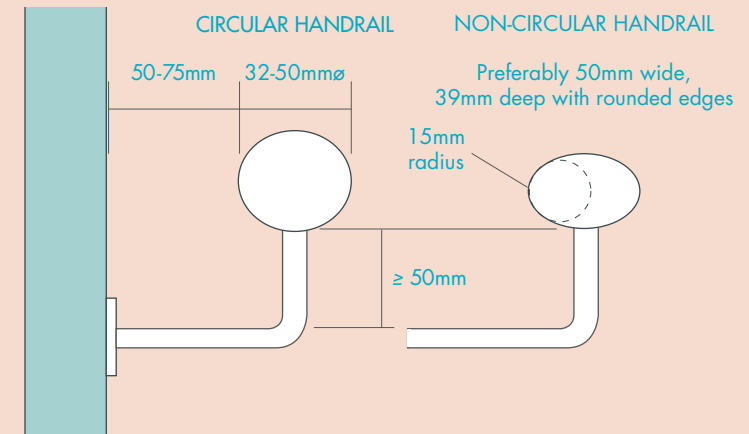

BS 8300-2 handrail dimensions

HANDRAIL

BS 8300-2 states certain dimensional criteria for the design of handrails.

In locations subject to extreme temperatures the handrail material must not become excessively hot or cold to touch whilst being of a material suitably robust to resist vandalism or misuse. Handrails with low thermal conductivity such as timber or nylon sleeved steel tube are most comfortable to touch in extremes of temperature. Handrails made from steel with low thermal conductivity such as stainless steel are suitable where resistance to vandalism or low maintenance is key.

9. VISUAL CONTRAST AND LRV

When specifying architectural ironmongery, it is important to consider the visual contrast between operable door furniture and the surface that it is mounted on, to ensure that they can be easily identified by those with visual impairments.

Example of door furniture with good visual contrast



Contrasting intumescent seals for leading edges of doors



WHAT IS VISUAL CONTRAST?

Visual contrast is the perception of a visual difference between one surface element of a building and another.

The main feature of a surface, which appears to be strongly correlated with the ability of visually impaired people to identify differences in colour, is the amount of light the surface reflects, or its light reflectance value (LRV).

LRVs are measured by using a hand held colorimeter or reflectometer of 0/45 degree geometry. BS 8493:2008 is the British Standard which describes the test method for measuring LRVs.

The LRV scale runs from 0 which is totally black to 100 which is perfect white.

VISUAL CONTRAST OF DOOR FURNITURE

BS 8300:2009 states:

“For easy identification by blind and partially sighted people, all door opening furniture should contrast visually with the surface of the door”.

It is considered that a difference in LRV between the door opening furniture and the door of at least **15 LRV points** is acceptable. If the LRV value of the door surface is subtracted from the LRV value of the door handle finish, this will give the differential.

DOORS LEADING INTO CORRIDORS

Where doors are held open, the leading edge of the door must contrast visually with the face of the door. Two examples of how this could be achieved are given:

- A contrasting intumescent seal of a minimum 15mm wide fitted in the edge of the door.
- A self-adhesive contrasting strip at least 1m long, starting at least 500mm from finished floor level, covering at least 60% of the door edge thickness.



Example of handrails with good visual contrast

HANDRAILS

BS 8300 states that handrails should be “finished so as to provide visual contrast with the surroundings”.

It states in Appendix B that generally there is considerable confidence in recommending differences in LRV of 30 points although 20 points might still be acceptable depending on surface illumination.

SIGNAGE

A difference in LRV of 70 points between letters, symbols or pictograms and the signboard is recommended. This is also recommended between the signboard and the background to ensure good visual contrast.

Light coloured text and symbols or pictograms on a dark background are preferred, while tactile features, Braille and adequate lighting will all assist those with impaired vision.



Guild of Architectural Ironmongers

The Guild of Architectural Ironmongers (GAI) is the only trade body in the UK that represents the interests of the whole architectural ironmongery industry - architectural ironmongers, wholesalers and manufacturers.

Formed in 1961, the GAI is internationally recognised and respected as the authority on architectural hardware, building its reputation on three key pillars; education, technical support and community.

Its technical information service is the only specialist service of its kind, providing comprehensive advice on issues relating to the legislation, regulations and standards governing the use of architectural ironmongery and related hardware.

RegAI - Pinnacle of Professionalism

A Registered Architectural Ironmonger (RegAI) is a fully qualified professional who has passed the GAI Diploma course and has completed the annual CPD programme.

Controlled by the GAI, the scheme offers the assurance that by working with a RegAI, you will be working with a professional that is fully up-to-date with the latest legislation, industry standards and products. RegAI status represents the highest possible standard of education and professionalism.

To find a RegAI to work with, check out the RegAI directory on the GAI website.